

Velociraptor

Designed by Jo Nakashima

<http://jonakashima.com.br>
<http://youtube.com/jonakashima>

Date: 19/Jul/2015
Difficulty Level: intermediate
Time to fold it: 20 minutes
Video: <http://youtu.be/9rOTQIuKolc>

Paper: 20cm x 20cm

- Standard paper
- Tissue foil
- Wet folding

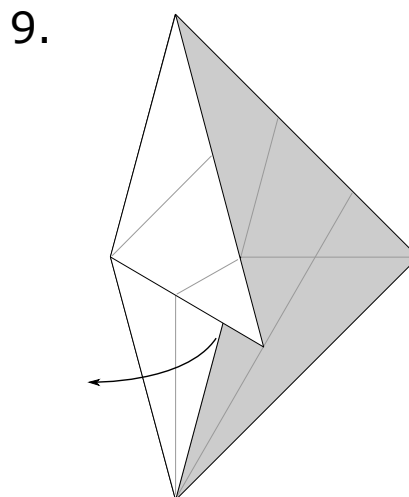
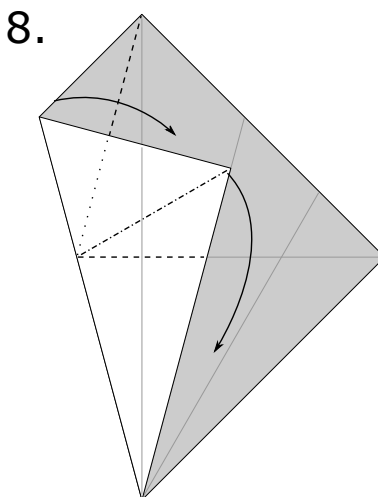
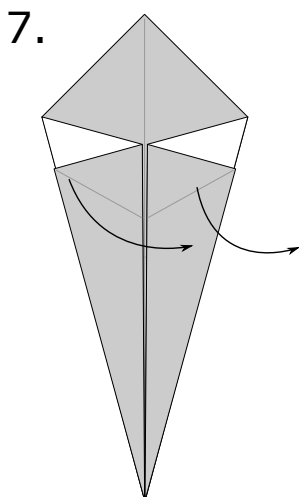
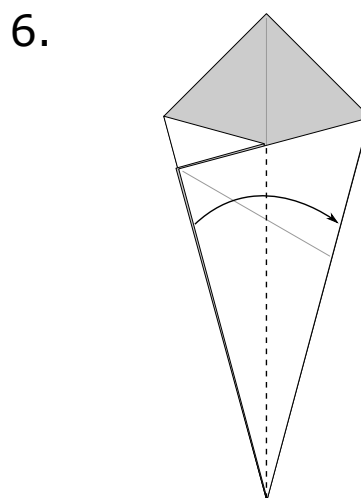
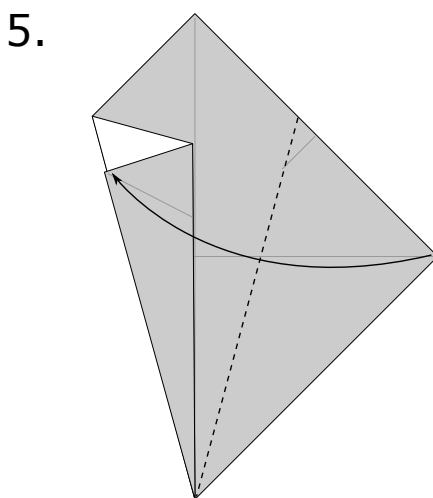
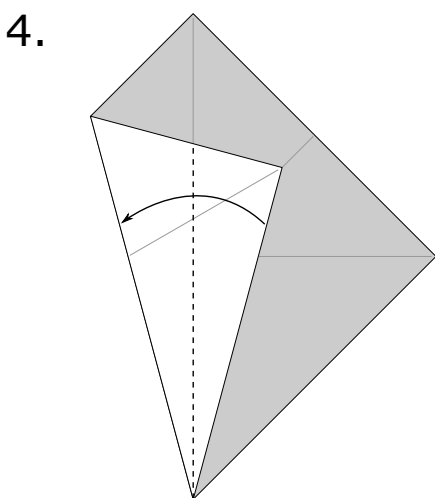
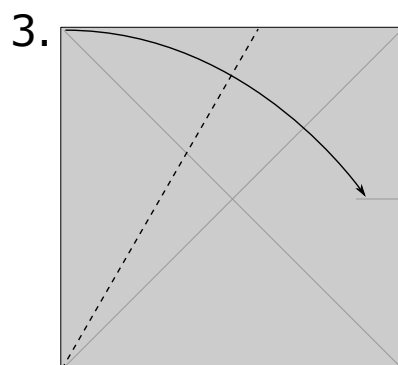
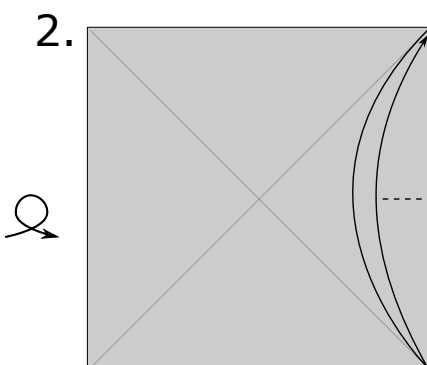
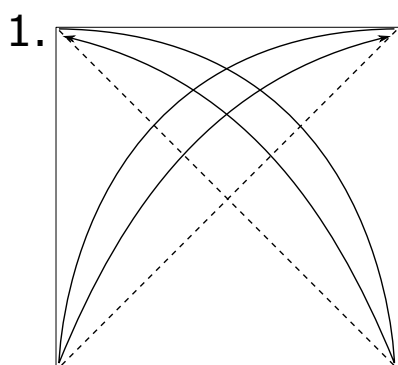

10.

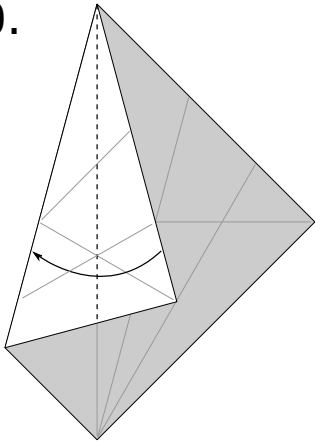

11.

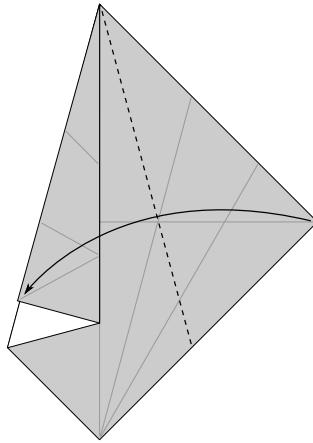

12.

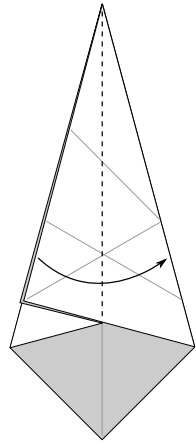

13.

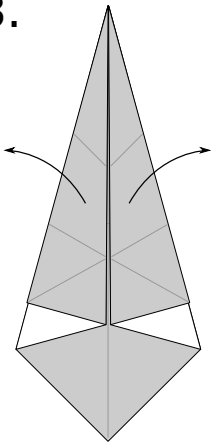

14.

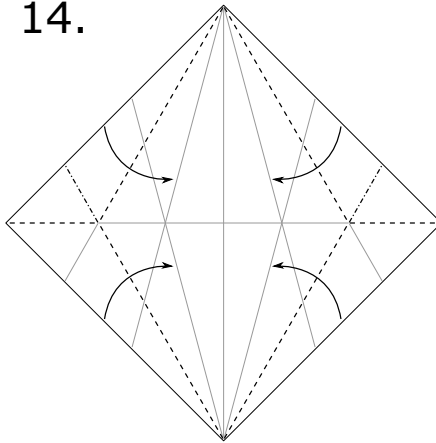

15.

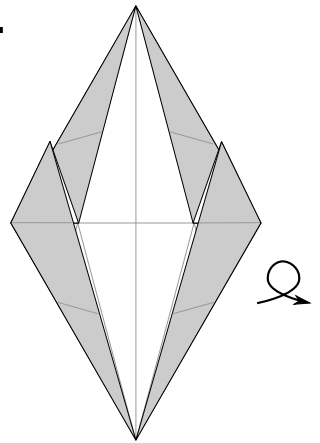

16.

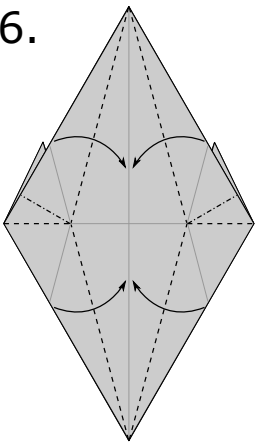

17.

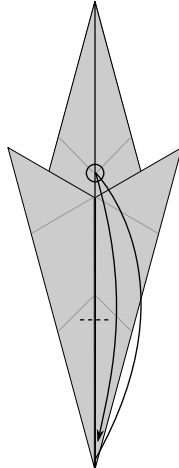

18.

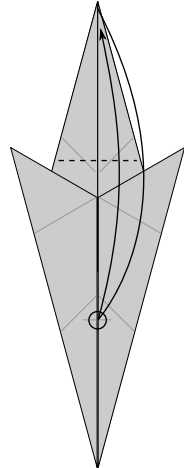

19.

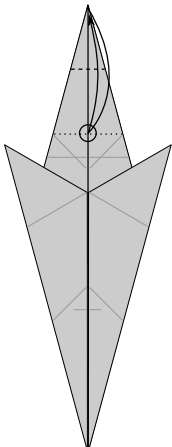

20.

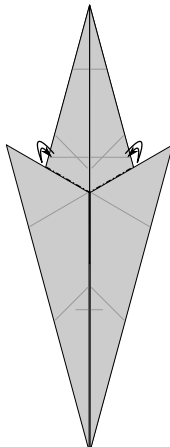

21.

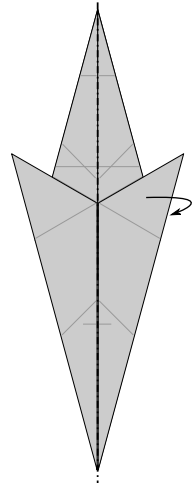

22.

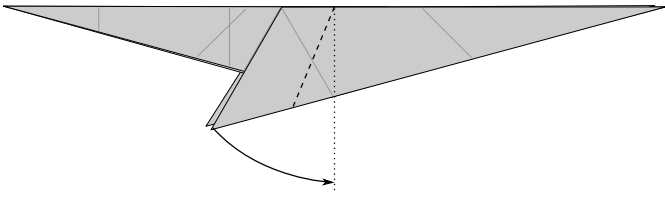

23.

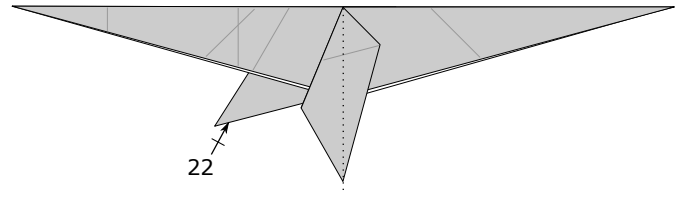

24.

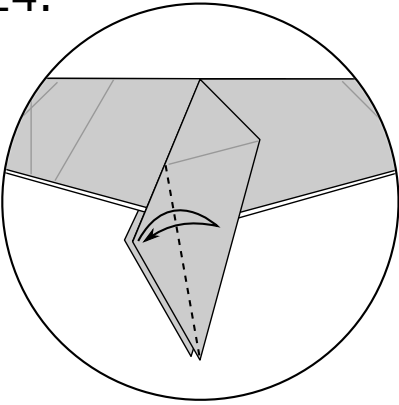

25.

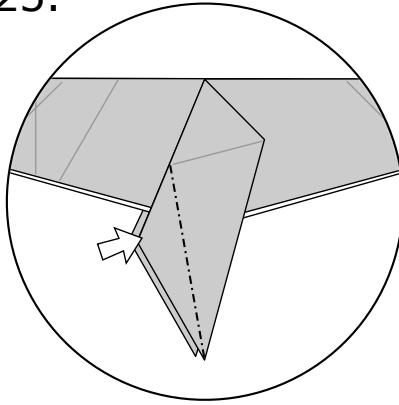

26.

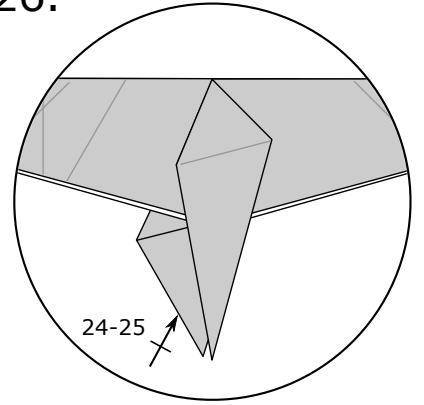

27.

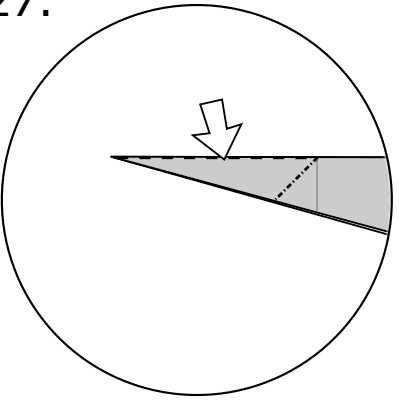

28.

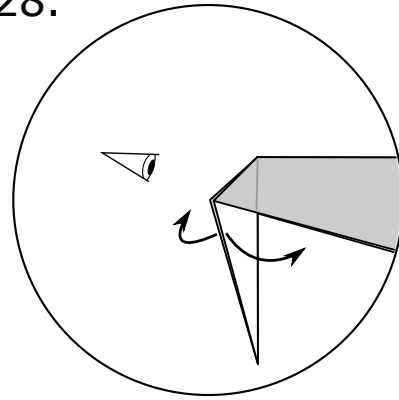

29.

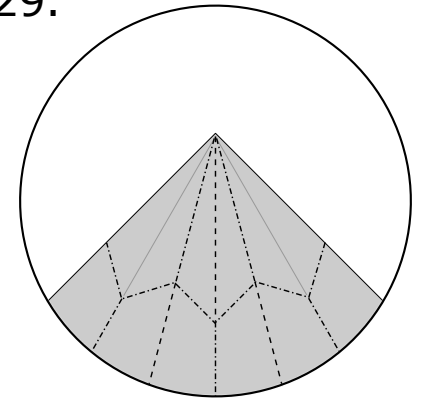

30.

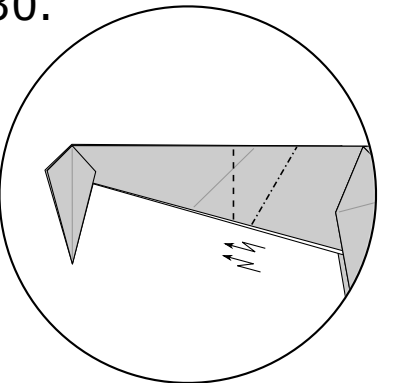

31.

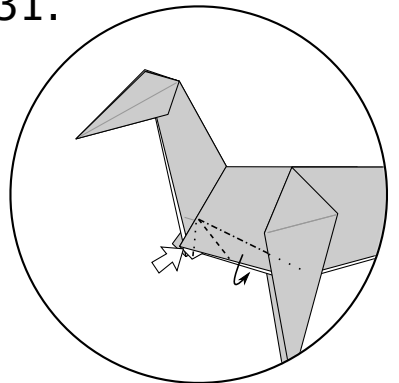

32.

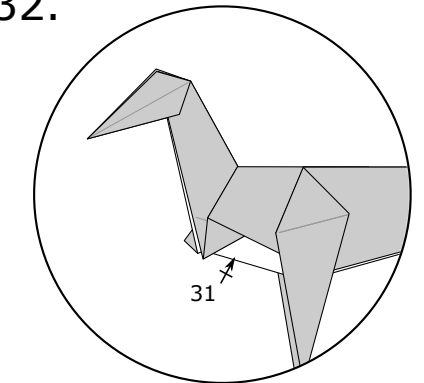

33.

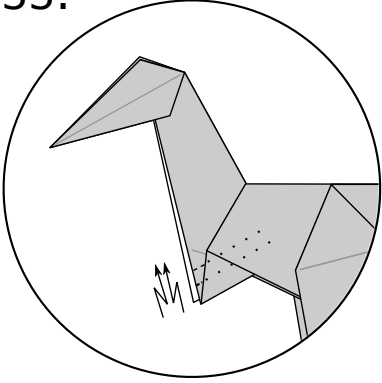

34.

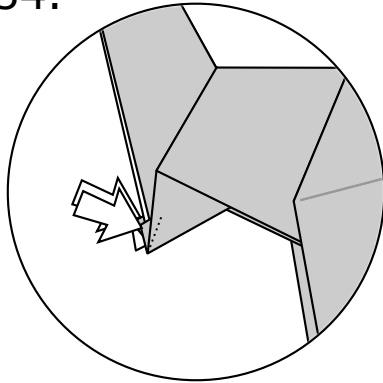

35.

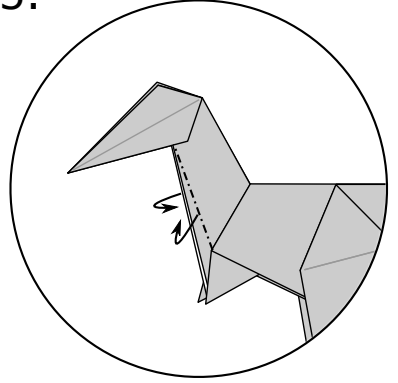

36.

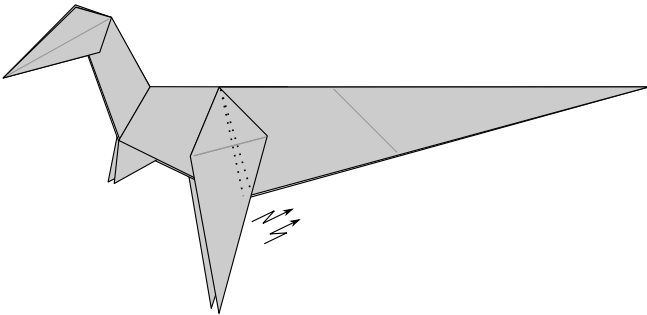

37.

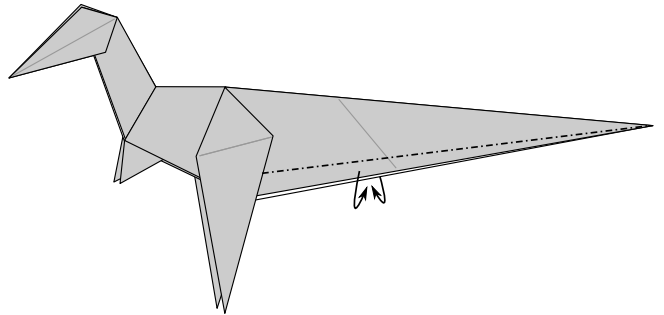

38.

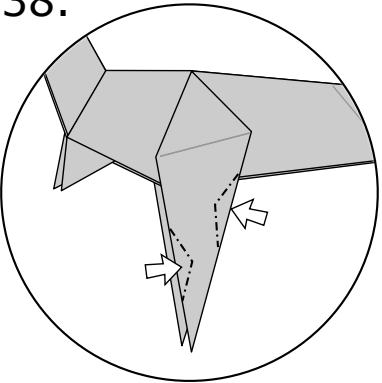

39.

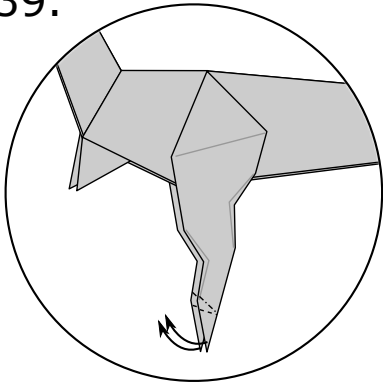

40.

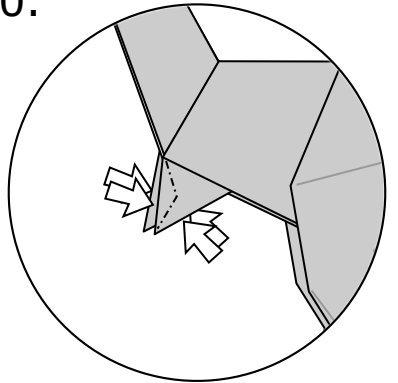

41.

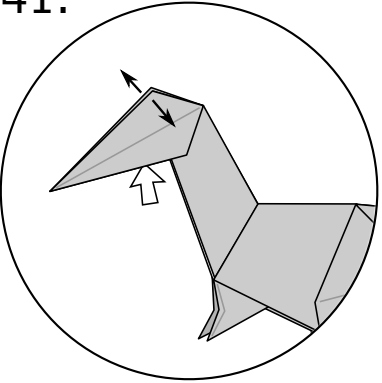

42.

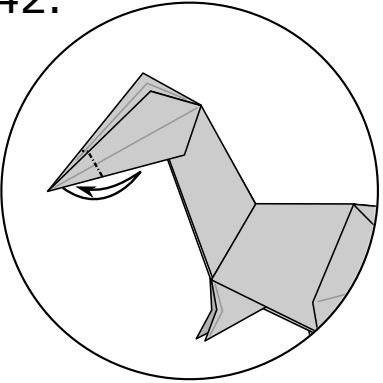

43.

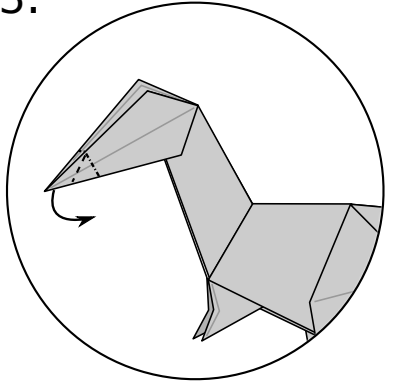

44.

