

# Chinchilla

Designed by Jo Nakashima

<http://jonakashima.com.br>  
<http://youtube.com/jonakashima>

Date: 13/Apr/2015

Difficulty Level: intermediate

Time to fold it: 25 minutes

Video: <http://youtu.be/mQ0KDBZHYxM>

Paper: 20cm x 20cm

Standard paper

Tissue foil

Wet folding

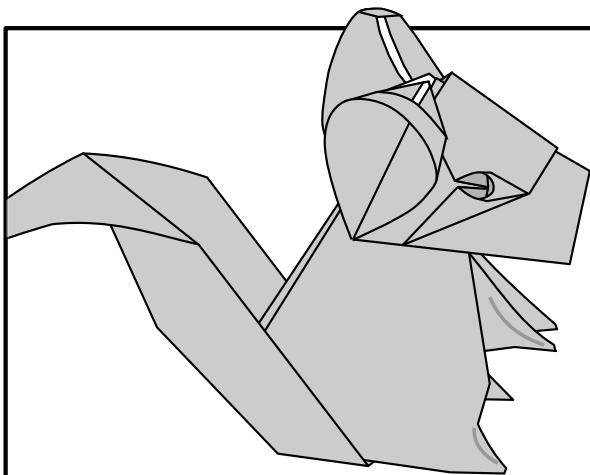

1.

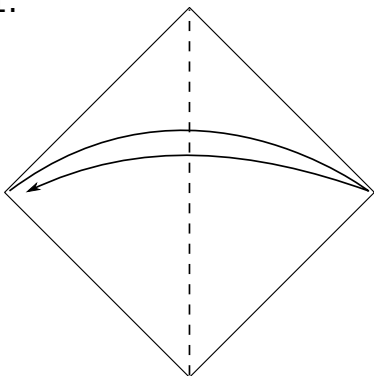

2.

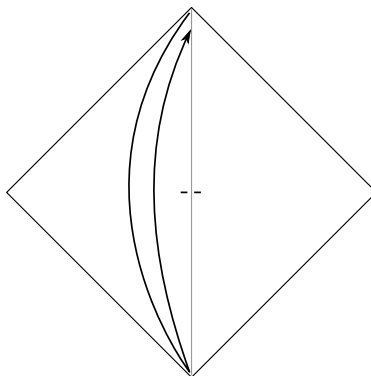

3.

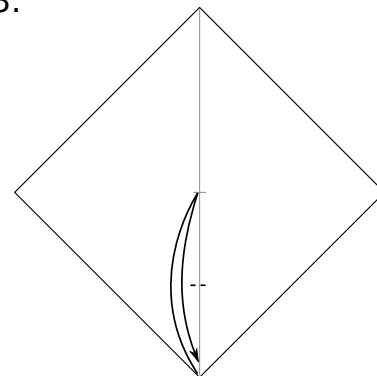

4.

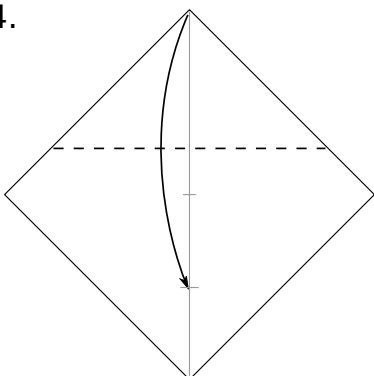

5.

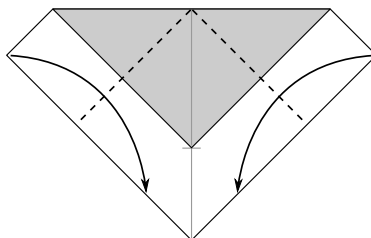

6.

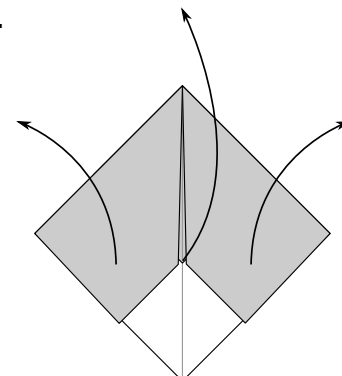

7.

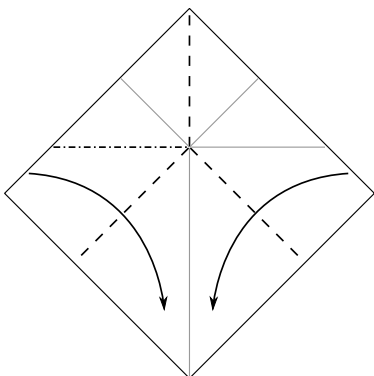

8.

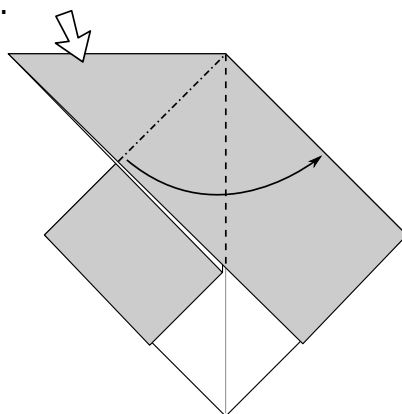

9.

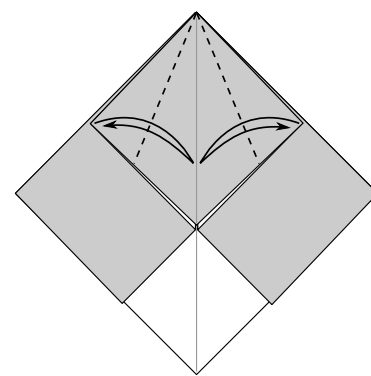

10.

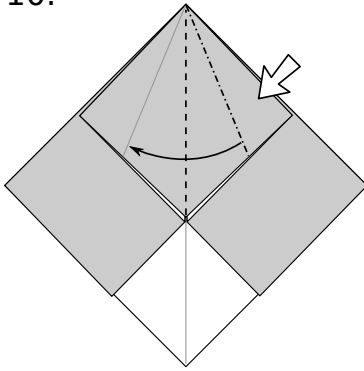

11.

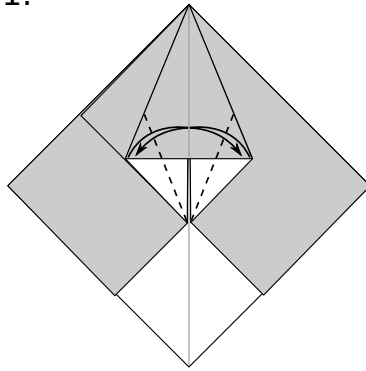

12.

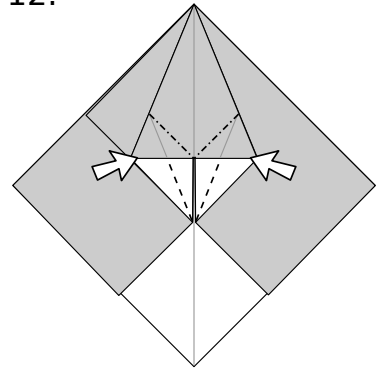

13.

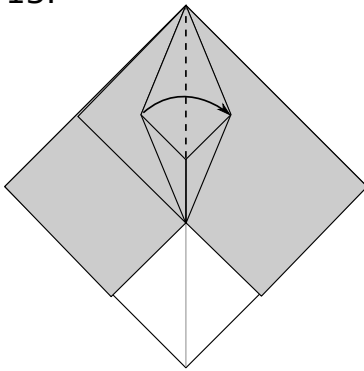

14.

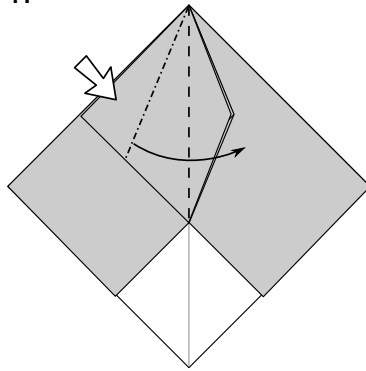

15.

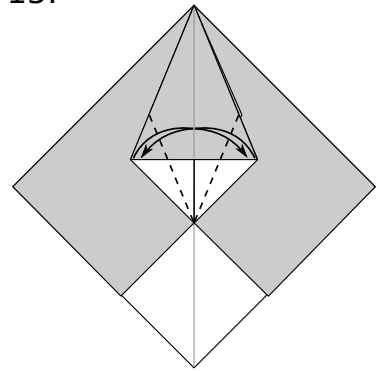

16.

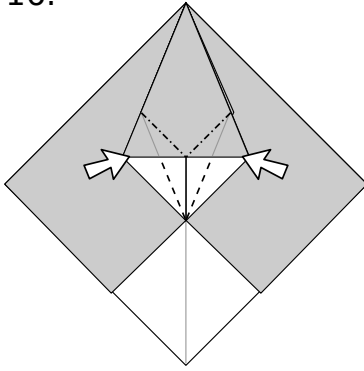

17.

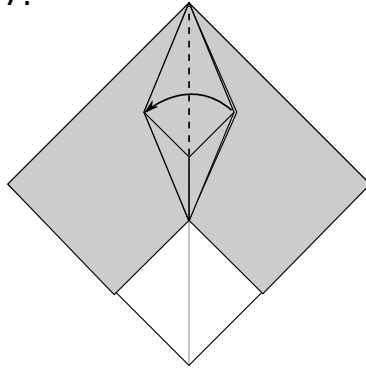

18.

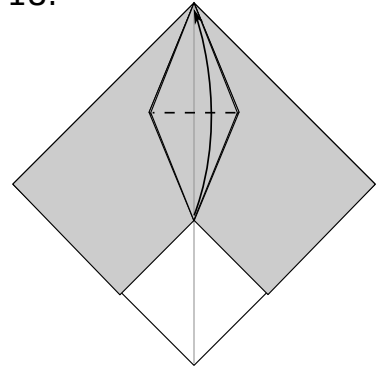

19.

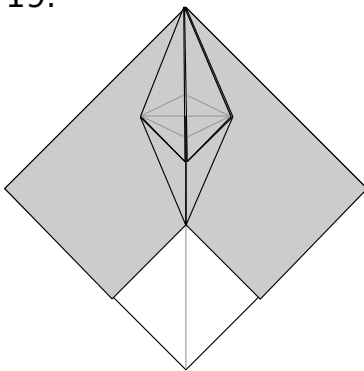

20.

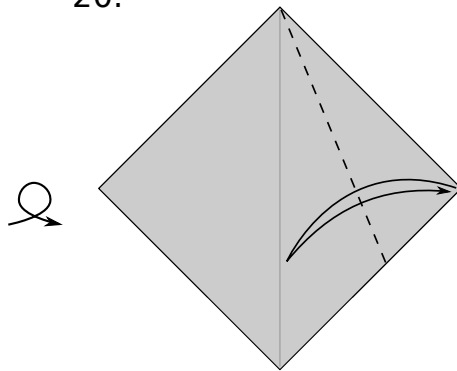

21.

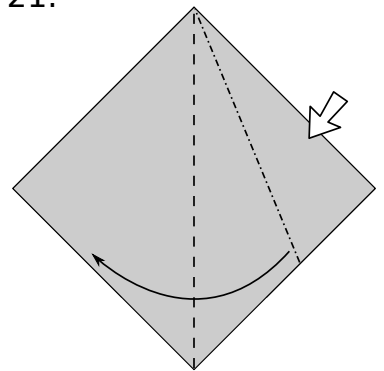

22.

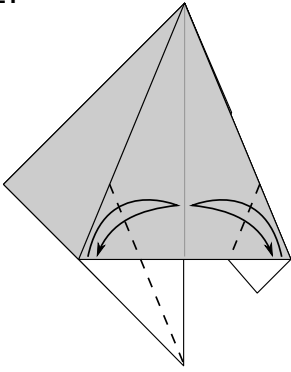

23.

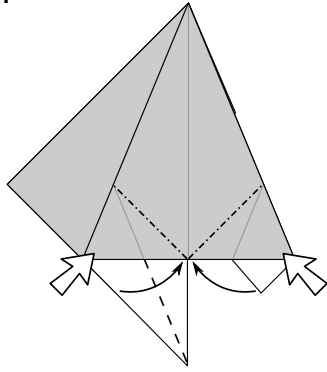

24.

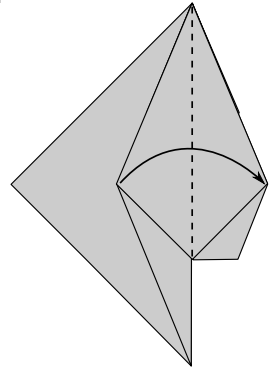

25.

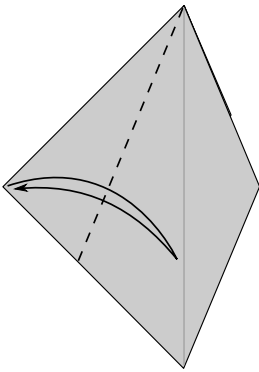

26.

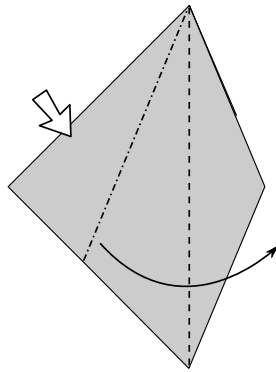

27.

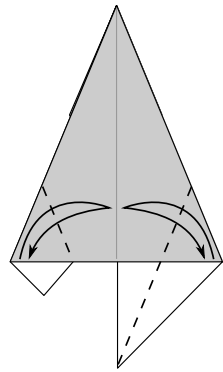

28.

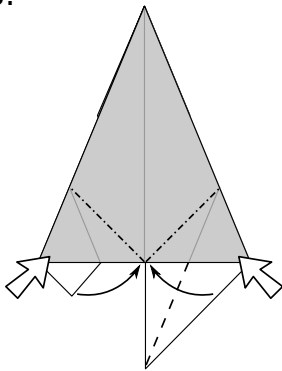

29.

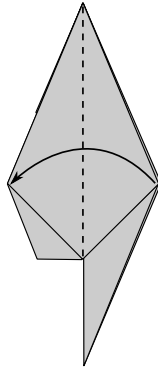

30.

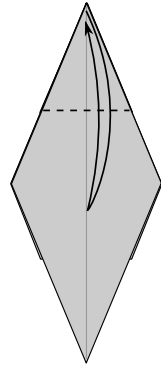

31.

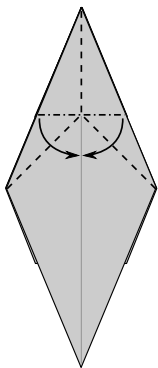

32.

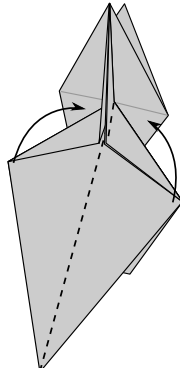

33.

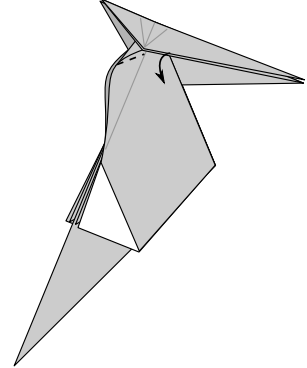

34.

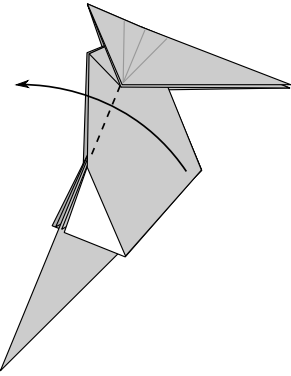

35.

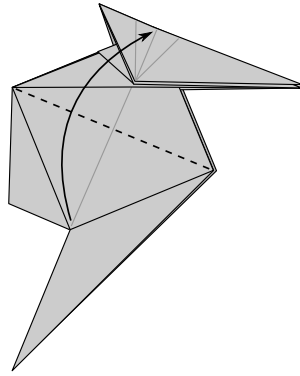

36.

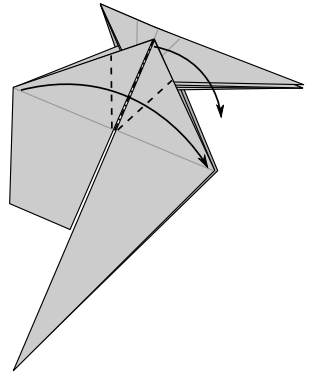

37.

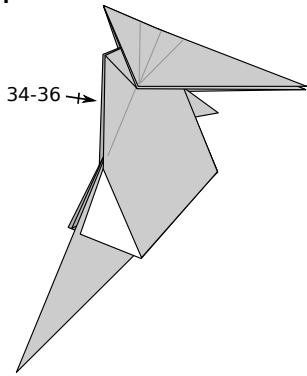

38.

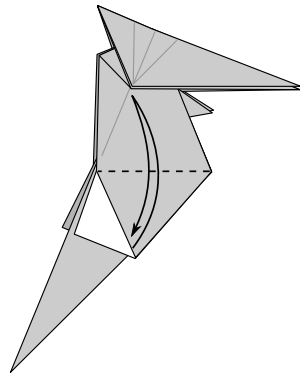

39.

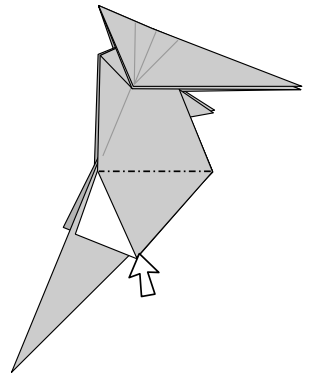

40.

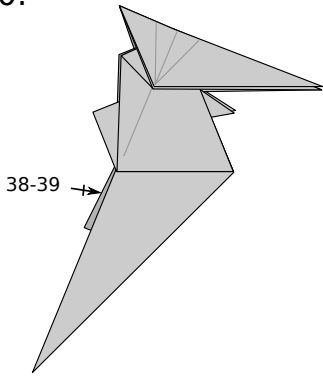

41.

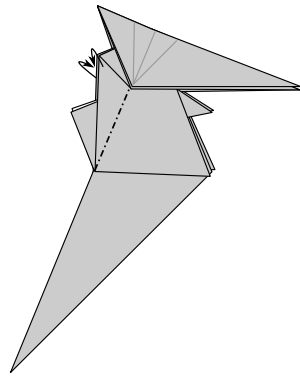

42.

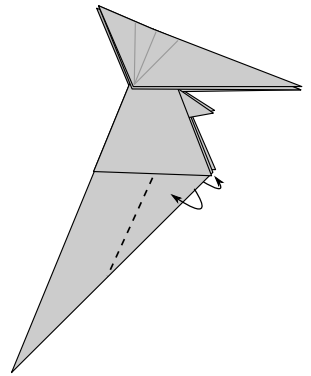

43.

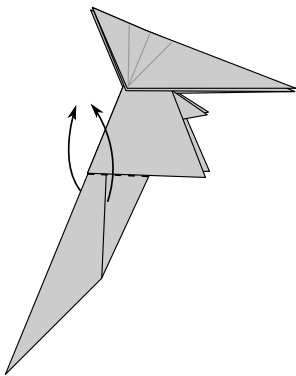

44.

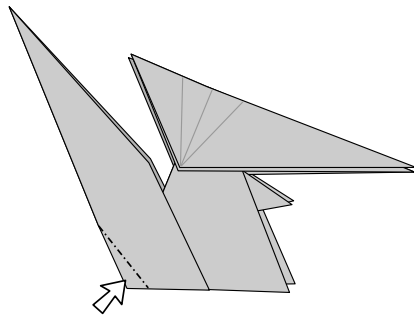

45.

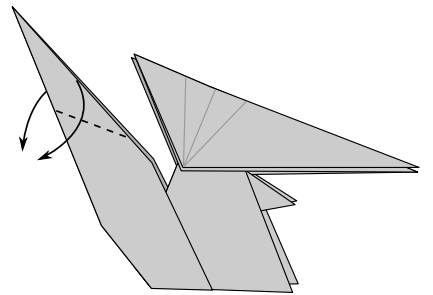

46.

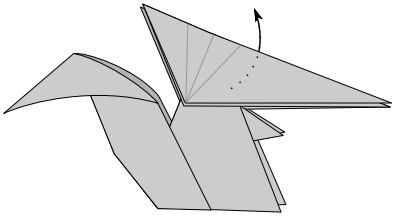

47.

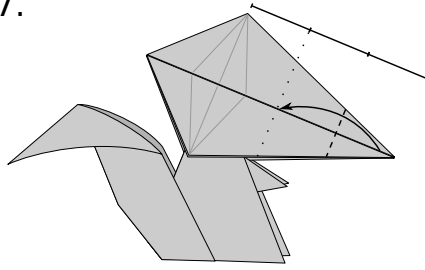

48.

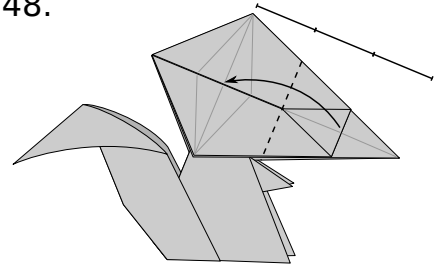

49.

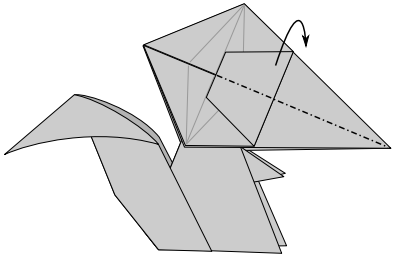

50.

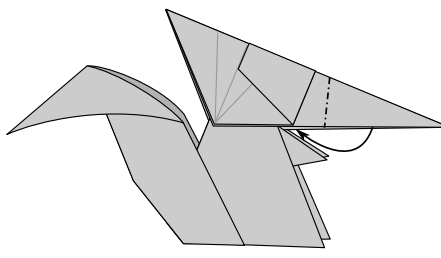

51.

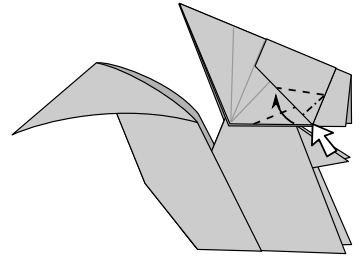

52.

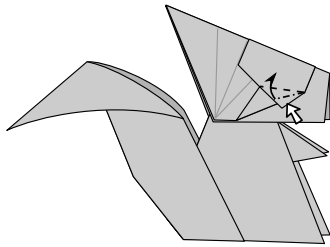

53.

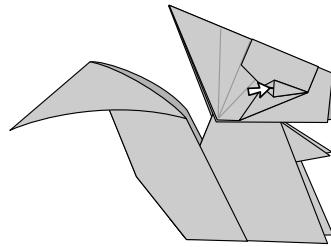

54.

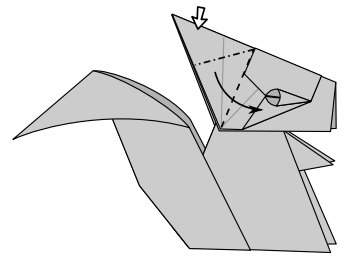

55.

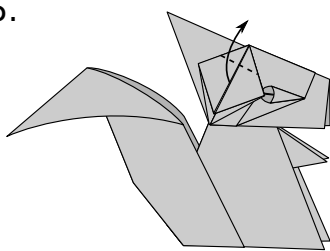

56.

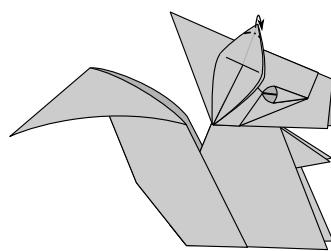

57.

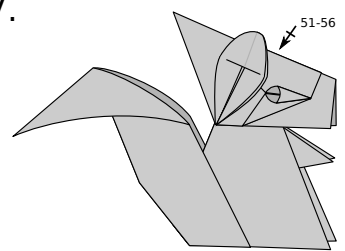

58.

