

# Mr. Heart

Designed by Jo Nakashima

<http://jonakashima.com.br>  
<http://youtube.com/jonakashima>

Date: 14/February/2016

Difficulty Level: 2/5

Time to fold it: 14 minutes

Video: [http://youtu.be/SF1X6RM\\_B4s](http://youtu.be/SF1X6RM_B4s)

Paper: 15cm x 15cm

Standard paper

Tissue foil

Wet folding

1.

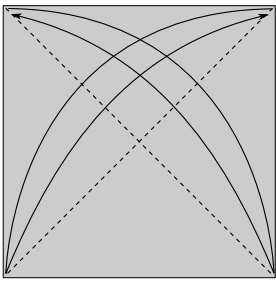

2.

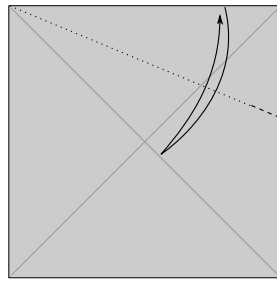

3.

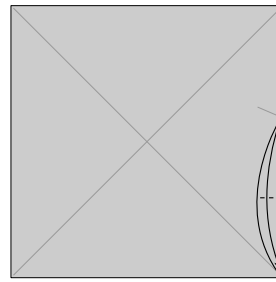

4.

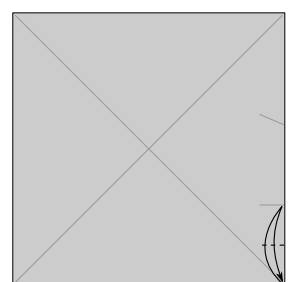

5.

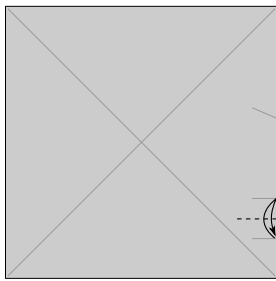

6.

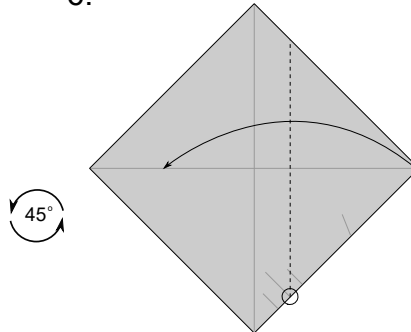

7.

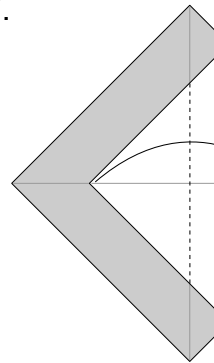

8.

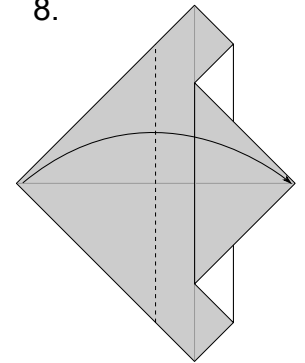

9.

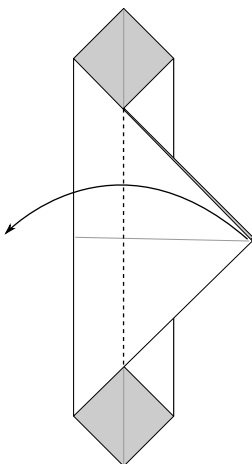

10.

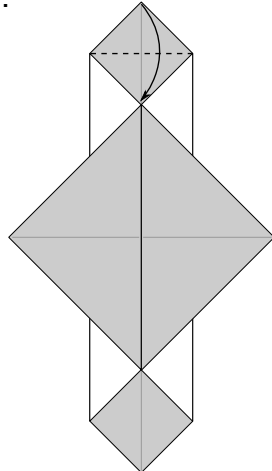

11.

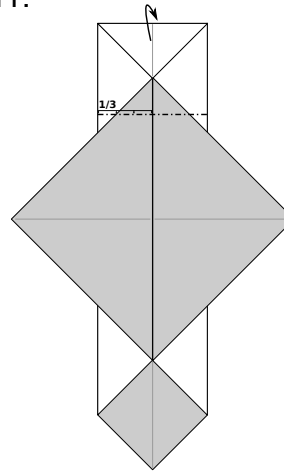

12.

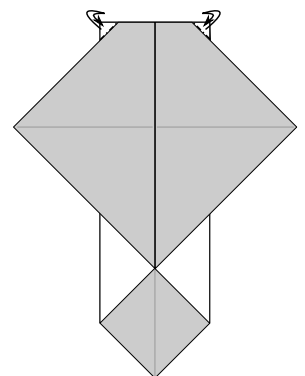

13.

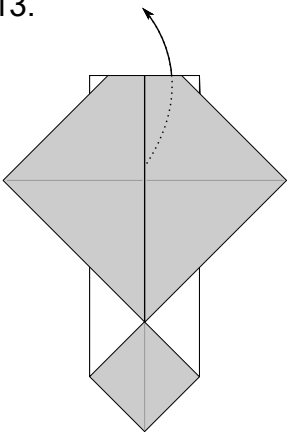

14.

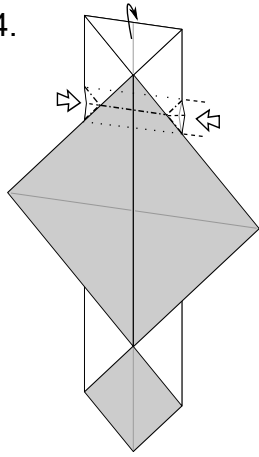

15.

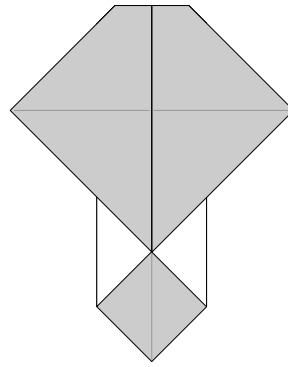

16.

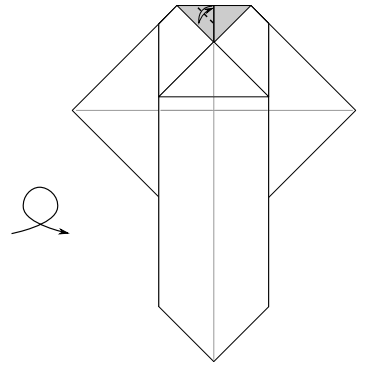

17.

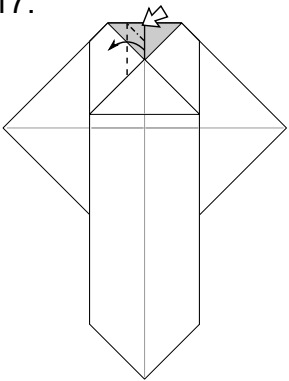

18.

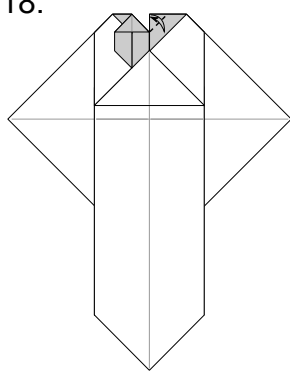

19.

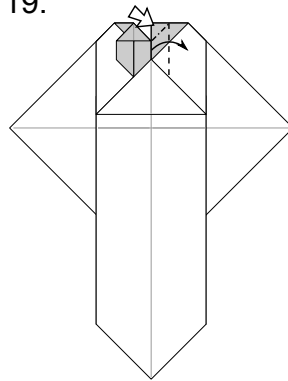

20.

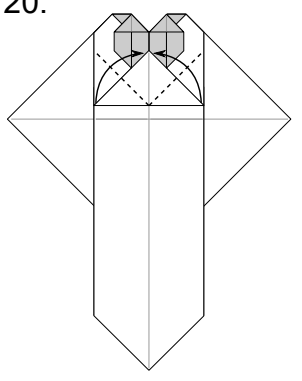

21.

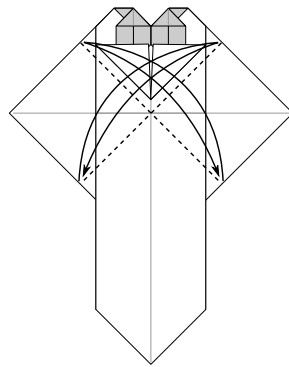

22.

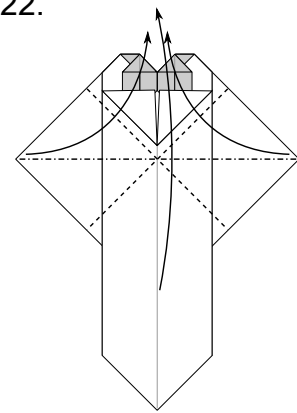

23.

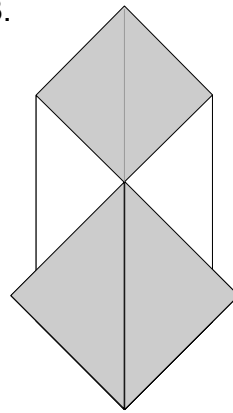

24.

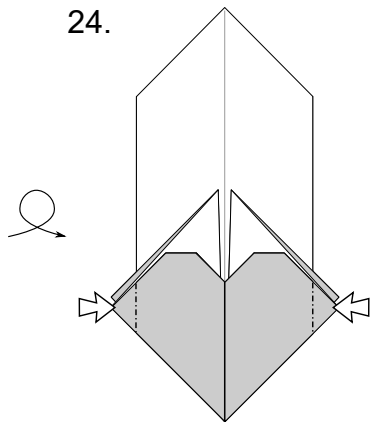

25.

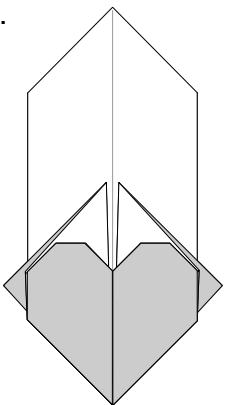

26.

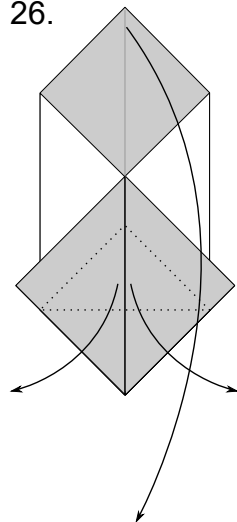

27.

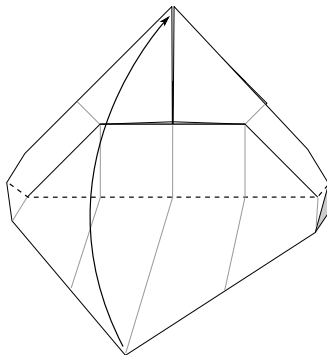

28.

